



Via Reggio Calabria, 13- 10090 Cascine Vica Rivoli (TO) - ITALIA
Tel. (0039) 011.959.16.01 Fax (0039) 011.959.29.62
E-mail: savio@savioclima.it



AXIAL FANS

INSTRUCTION AND MAINTENANCE

HANDBOOK

The instruction manual is an essential and integral part of the machine and must be kept by the user. If the fan is sold or transferred to a new owner, always ensure that the instruction handbook accompanies the fan, so that the new owner or installation personnel can consult it. Should the handbook be lost or destroyed, a replacement copy may be obtained from the manufacturer. Please read the information contained in this handbook and carefully follow the instructions pertaining to safety measures during installation, operation and maintenance. All installation operations must be carried out by qualified personnel, in keeping with applicable norms and the manufacturer's instructions. The term "qualified personnel" means and includes any and all staff with specific and specialised qualifications in the various technical fields that come together to make up the plant: electrical, hydraulic, heating, conditioning, etc., in industrial environments. Incorrect installation may provoke damage to persons, animals and things. The manufacturer declines any and all responsibility for such damage.

1) INSTALLATION

1.1) Shipment acceptance and packaging

Check the state of the packaging.

If there are signs of damage to the packaging, check the contents and make note of all reservations in writing on the freight bill.

Any and all claims for damages occasioned during shipment must be communicated to the carrier within 24 hours of receiving the goods.

All packaging elements (crates, nails, straps, etc.) must not be abandoned but carefully disposed of since they are potential safety hazards.

1.2) Transport

For bigger fans, use the hooking attachments provided and check that all cables are of equal length to ensure that the fan is perfectly balanced during shipment.

1.3) Storage

Do not store the fan

- In humid places
- Close to machines that generate vibrations

Always ensure that the fan is protected from rain and excessive heat. Carefully cover the motor, bearings, shafts, drives and all electrical accessories. If the fan is stored for long periods of times (months or years), bearing grease must be changed once a year.

1.4) Foundations

Perfectly levelled reinforced concrete foundations are recommended for high-pressure blowers, and high speed or heavy fans.

Antivibration material should be placed under the fan to reduce the vibrations generated by rotating parts.

Our technical dept. would be happy to provide advice on the choice of material.

1.5) Securing the fan

All fixing points must be used. While tightening fixing bolts, ensure that the fan or blower structure is not deformed.

1.6) Technical features

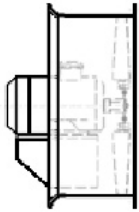

SPM

Conveyance casing in high-gauge sheet steel (Fe 37), fitted with streamlined nozzle and single flange
Impeller with blades in Aluminium alloy or resin (glass-charged polypropylene).

Hub in Aluminium

Diameter sizes: 315 through 710 mm

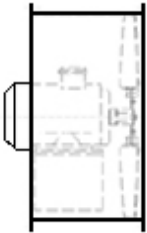

SPMD –SPMDR

Conveyance casing in high-gauge sheet steel (Fe 37), fitted with double flange
Impeller with blades adjustable from standstill state.

Hub :

SPMD in Aluminium

SPMDR with steel sealing plates and Aluminium inserts

Diameter sizes: 800 through 1400 mm (Spmdr 1600 mm)

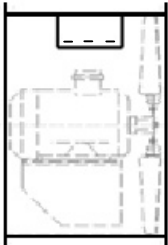

SI – SIR

Long conveyance casing in high-gauge sheet steel (Fe 37), fitted with double flange and inspection door
Impeller with blades adjustable from standstill state, starting from 710 mm diameter inclusive.

Hub :

SI in Aluminium

SIR with steel sealing plates and Aluminium inserts.

Diameter sizes: 315 through 1400 mm (Sir 1600 mm)

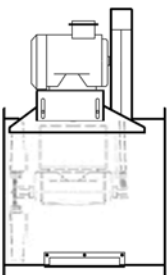

SIT

Long conveyance casing in high-gauge sheet steel (Fe 37), fitted with double flange and inspection door, fitted with an external base for a chain stretcher device and motor attachment and protective casing for the transmission.

Hub in Aluminium

Diameter sizes: 315 through 1000 mm

2) START UP

2.1) Safety checks

Before starting the machine a series of safety checks should be carried out.

Check that all fixing bolts of the foundations, the impeller, support structures, motor and various protective shields (grids, carters, etc.) are tightened.

Manually turn the impeller and check that all moving parts (impeller, gears, shaft) are not hindered by obstacles.

Before connecting the fan to the mains, check that the connecting terminal voltage is the same as the mains voltage.

Ensure that the earthing screws on the motor base and on the terminal board are connected to the earthing socket.

2.2) Electric connections of the motor

Ordinary protection system with direct motor start-up.

230/400 V

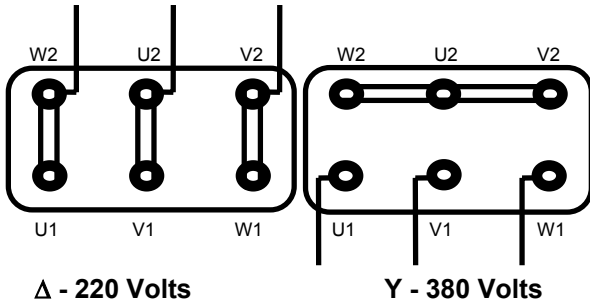

400/690 V

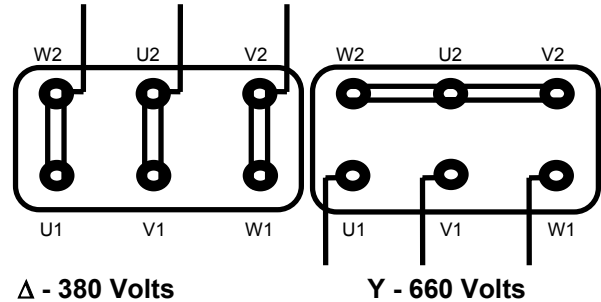

290/500 V

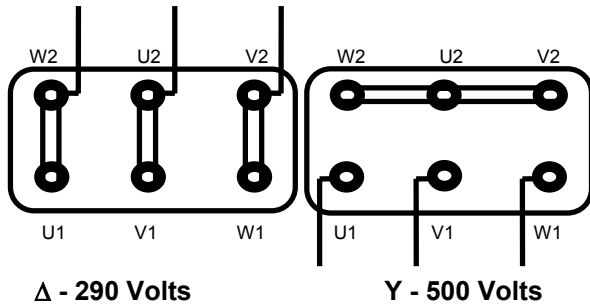

500/865 V

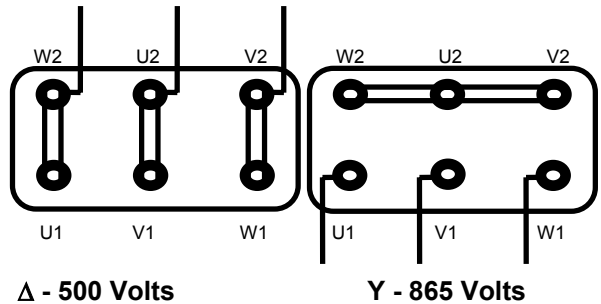

The following fig. shows the connection for start-up using the YΔ switch

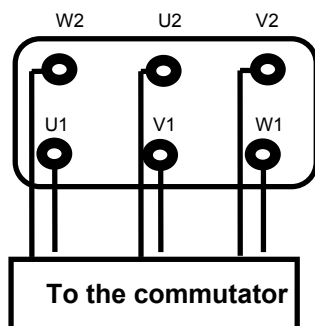

N.B.:

The electric equipment should include protections for an overload and tension fall, chosen to match the effective start-up time and full-load current

IMPORTANT: According to the CEI 17-7 norm, a differential type temperature relay, capable of detecting phase differences, must be used.

NOTE: The term "differential" in this context refers to the mechanical device that causes immediate cut-off in case of a lack of phasing and has nothing to do with the same term used to describe "life preserving" type automatic switches.

Mechanical overload, transformed into electrical overload equally distributed over the three phases, can be controlled by an ordinary temperature relay. The fault, during single-phase operation, is controlled by a "differential" temperature relay that can detect loss of phasing.

If one of the three conductors fails, an asynchronous tri-phase motor, once started, continues operation. In fact, the magnetic field generated by the stator windings give rise to driving torque, albeit modest, causing a considerable rise in motor temperature.

If single-phase operation is not cut-off within a few minutes, the motor is irreversibly damaged because of deterioration of insulating material. Single-phase operation can be caused by wiring defects, (loose connecting terminal, broken wire, bad connections, etc.), but the most common cause is the fusion of a single of the three fuses placed upstream of the motor to protect against short-circuiting.

Therefore the first and most important measure against single-phase operation consists in avoiding the use of fuses.

While choosing the parameters of the thermal magnetic switch, bear in mind that peak current can reach 6.5 times the nominal value during direct start-up.

For instance, a 7.5 Kw motor with a nominal current of 15.5 Amp. (380V) can peak to 100 Amp. (6.5 X 15.5) during direct start-up.

During star-delta starting, current absorption is limited to 2.2 times nominal value.

Therefore during the star-delta passage, peak current can reach 4.5 times nominal value.

2.3) After start-up check:

- That the rotation direction is the same as that indicated by the arrow

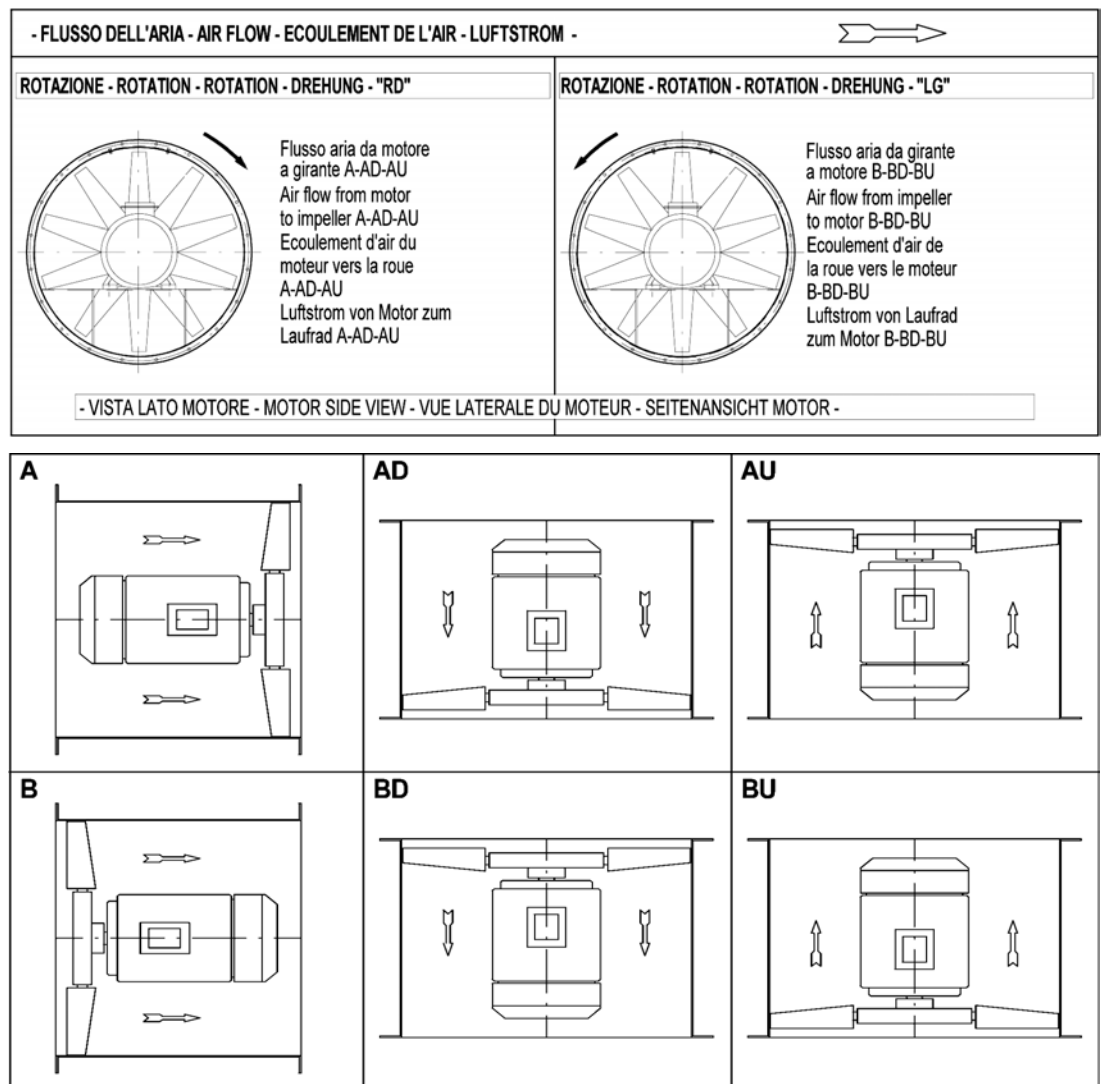

- That the absorbed current does not exceed the value on the rating plate
- Che that no anomalous vibrations are present.
- That the temperature of the support bearings is normal (after a temporary rise during initial start-up the temperature should drop over the next few hours).
- After a few hours of operation, check that the belts are correctly tensioned and correct them if necessary.

Attention:

- Repetitive and consecutive starting of the motor must be avoided as far as possible.
- No indication of the strict max. start-ups per hour can be calculated since this value depends on various factors such as: power, revolutions, PD2, installation conditions, etc.
- Measure the absorbed current on one of the three line conductors. In star-delta connections, this value must be read upstream of the switch. If this is not possible, read the phase current on any one of the six conductors at the terminal board and multiply the value read by 1.73.

1) MAINTENANCE**3.1) Impeller**

Before to act on the impeller, wait minimum 5 minutes after fan stopping so electrostatic charges will be exhausted.

Periodically clean and remove all traces of incrustations and/or dirt that could imbalance the impeller. Check the state of wear and tear on the impeller, especially if the fan is used to transfer abrasive powders or aggressive gases.

Bear in mind that wear and tear on mechanical and/or resin parts can give rise to dangerous loss of balance that could break the impeller. If there are signs of wear and tear, it is advisable to replace worn parts immediately.

3.2) Conveyance casing

Carefully clean the internal parts removing all foreign particles.

3.3) Pulley (mod. SIT)

Pulleys must be perfectly balanced to avoid vibrations that rapidly damage bearings.

Check that the pulleys are correctly aligned and that this operation is carried out carefully. Carefully clean the grooves.

3.4) Belts (mod. SIT)

Clean each side WITHOUT solvents and / or abrasive products. In case of wear, it's necessary to replace the belts and to verify the belts tension if it's necessary.

Belts tension adjustment instruction:

The correct functioning of a belt drive is closely related to correct tensioning at installation.

Installation must therefore be carried out in the following manner, using the slide tightener:

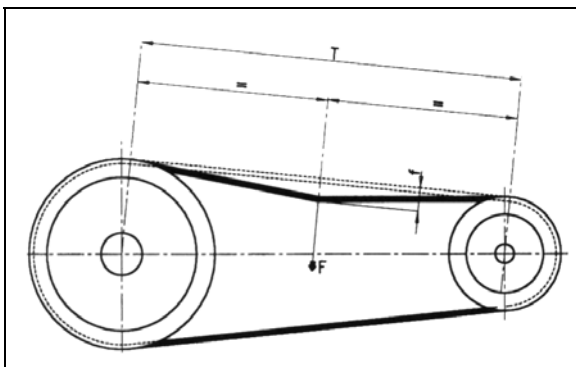

- 1) Measure the free distance **T**
- 2) Using a dynamometer apply a perpendicular force to each belt, so as to produce an arc **F** of 1.5 mm. for every 100 mm. of **T**.
- 3) Compare the value **F**, read by the dynamometer, with values of **F'** and **F''** provided in the table.

Belt Drive	Diam. Est. pulley min. (mm)	Nr. RPM pulley min.	F' min. Newton	F'' max Newton
SPZ	50 ÷ 90	1200 ÷ 5000	10	15
	100 ÷ 150	900 ÷ 1800	20	30
	155 ÷ 180	600 ÷ 1200	25	35
SPA	90 ÷ 145	900 ÷ 1800	25	35
	150 ÷ 195	600 ÷ 1200	30	45
	200 ÷ 250	400 ÷ 900	35	50
SPB	170 ÷ 235	900 ÷ 1800	35	45
	250 ÷ 320	600 ÷ 1500	40	60
	330 ÷ 400	400 ÷ 900	45	65
SPC	250 ÷ 320	900 ÷ 1800	70	100
	330 ÷ 400	600 ÷ 1200	80	115
	440 ÷ 520	400 ÷ 900	90	130

N.b.:

- 1) The table refers to belt drives with a ratio of 2 to 4. Where $F < F'$ the belt must be tensioned further. Where $F > F''$ the belt is too tight.
- 2) During the breaking-in phase of the belt drives, tension tends to fall rapidly. It is therefore necessary to tension the belts at installation, so that the force that generates the arc F is 1.3 times the value indicated in the table. Also frequently check belt tension.

3.5) Supports

In normal working conditions, re-lubrication should be carried out at the intervals TF shown in Diagram 1, in function of the bearing revolution speed N and of the diameter d of its hole.

The diagram is valid for horizontal shafts. High quality lithium grease must be used at a temperature that does not exceed 70°C at full working speed.

To compensate for the increased aging rate of grease at higher temperatures, the re-lubrication intervals indicated in the table must be halved for every 15°C of the working temperature of the bearing, in excess of 70°C . In normal working conditions, where temperature is not raised by external heat sources, the quantity of grease to be used can be obtained by applying the formula:

$$GP = 0.005 \times D \times B$$

Where GP = quantity of grease to be used, expressed in grams.
 D = external diameter of the bearing, in mm.
 B = total width of the bearing, in mm.

The type of grease, except where expressly otherwise indicated, is **KLUBER STABURAGS N. 12**

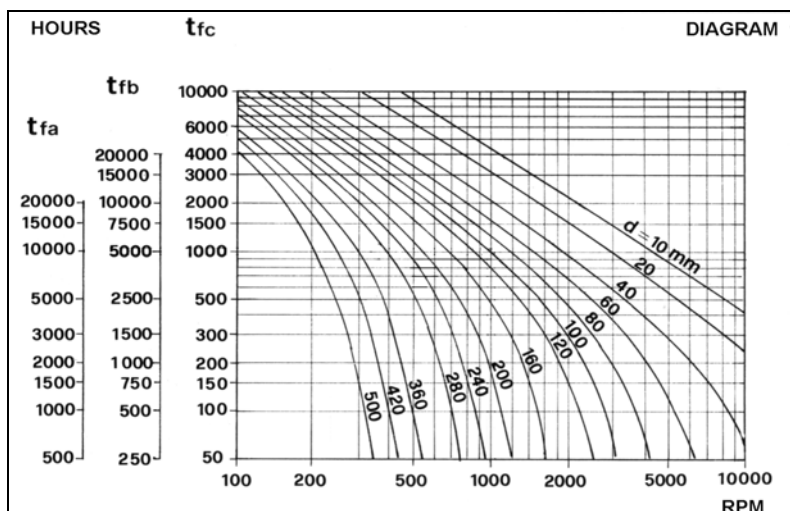

t_{fa} = Radial bearings to spheres

t_{fb} = Bearings to seams and cylindrical seams

t_{fc} = Adjustable bearings to seams, bearings to conical seams

4) DISMANTLING

4.1) Impeller

In order to remove the impeller, it's necessary to disassemble the protection grids and / or the piping from impeller side because it's not possible to remove this component from motor side.

The motor support or hanger transmission on SIT model are directly welded on fan casing.

To remove the impeller from the motor shaft or from the support shaft, use the extractor as shown in **FIG. 9**

Fig. 9/A Unscrew the screw **a** and remove the seal **b**

Fig. 9/B Screw a screw on to the motor shaft and place the extractor **c**, and using the supports (**d**) placed on the impeller hub, remove the impeller

Fig. 9/C To mount the impeller, place the impeller on the shaft (**e**), apply slight pressure so that impeller locks onto the shaft, then tighten the screw **a**.

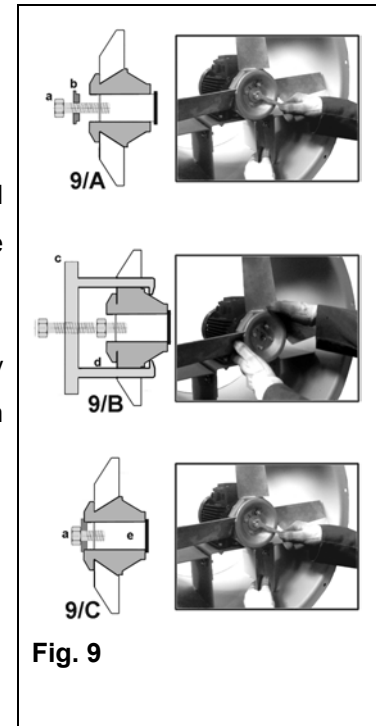

4.2) Pulley and Belts (mod. SIT)

Disassembling pulleys instruction

Remove the drive belts by loosening the belt tighteners, dismantle the pulleys as shown in **FIG. 10 A /B /C**

Fig. 10/A Unscrew the screws **a** and **b**

Fig. 10/B Screw the screw **c**, until the pulley bushing is totally released. Remove the bushing.

Fig. 10/C To re-mount, place the bushing and the pulley on the shaft (**e**). Then tighten the screws **a** and **b**, until the bushing-pulley-shaft group is completely secured

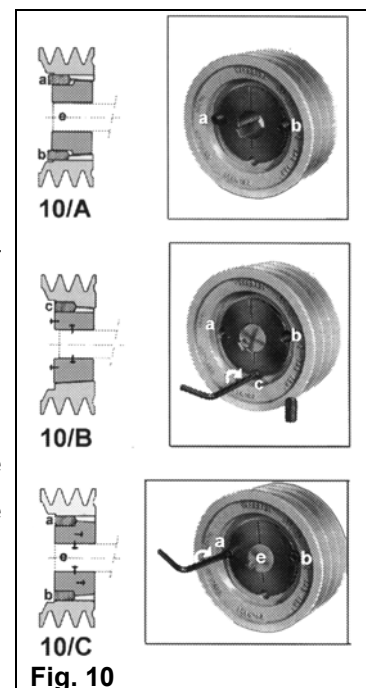

5) GENERAL FUNCTIONING NORMS

5.1) Technical information on the functioning of the fan

If circuit resistance exceeds calculated values, the fan flux will fall under the indicated value and the motor will absorb reduced power.

If circuit resistance falls short of calculated values, the fan flux will exceed the indicated value and the motor will absorb greater power.

It is therefore recommended to install a calibration air lock on the circuit to adjust the ventilation system during the start-up phase.

The max. power absorption point is obtained as the fan approaches the max. yield point.

The above recommendations concerning the use of an air lock for circuit resistance adjustment remain valid.

5.2) Noise

Noise level values are expressed in our technical documentation in L_p : Noise level in dbA, measured in a free field at 1.5 mt from the source with connected canalizations, at the indicated flux and head levels, with the flux transported in standard conditions, 20°C at 1 atmosphere.

On fans installed in industrial environments, it is nearly impossible to obtain noise levels identical to the readings under standard conditions.

This is because of the various types of installation conditions found in industrial complexes. When measuring noise levels in industrial environments, bear in mind that the noise source may be installed in noise reflecting, reverberating or amplifying conditions. For a source installed on a perfectly reflecting flat surface such as concrete flooring, 3 dB must be added to standard values. For a source installed at the intersection of two perfectly reflecting flat surfaces such as in the case of a floor meeting a lateral wall, 6 dB must be added.

For a source installed at the intersection of three perfectly reflecting flat surfaces, such as a corner, 7 dB must be added.

All the above values are merely approximate, but are generally used for engineering calculations.

Upon request and on condition that all installation data are made available, the manufacturer will advise the client on the necessary measures to contain noise levels, which must fall within the limits imposed by EEC norms.

5.3) Protecting the motor

Besides calling to mind the information concerning the electrical connections for the motor, we must underline that **the electrical parts of the motor are not covered by guarantee**. If the mains supply connections are carried out in keeping with current norms, with all the protective and safety devices and if such protection has been correctly adjusted, it is nearly impossible for the motor to be damaged or develop faults.

5.4) Safety devices against the risks of accidental contact

All moving parts are protected against risks of accidental contact in keeping with UNI 9219 norms.

The air inlets of the suction and pusher fan are generally supplied without protective meshes since it is presumed that they will be attached to tubes or housed in cabins.

If the air inlets of the suction and pusher fan are not connected to tubes, **it is absolutely necessary to install safety meshes.**

The user must ensure that all protective and safety devices, especially the protective carters for drives and the cooling fan, are correctly installed before start-up. **It is absolutely prohibited to start the machine without these protections.**

It is strictly prohibited to open inspection doors when the fan is in operation. Even door closures must take place with the machine off. All maintenance operations must be carried out under max. safety conditions for personnel.

Installation must be carried out bearing in mind the risks involving the introduction of foreign bodies, explosive and inflammable gases into the circuit.

If these risks are not contained within the standard limits applicable, a hazardous situation with risks of explosion or permanent and irreversible damage to the fan, may result.

Our technical office would be happy to advise you on the choice of fan best suited to your needs.

Our production range is vast enough to satisfy all your needs for the transfer of explosive or dust-laden gaseous substances, even with large or filamentous bodies in suspension.

Each fan must be used only for the application for which it was specifically designed.

Any and all other uses are to be considered incorrect and dangerous.

The manufacturer declines any and all responsibility, contractual or otherwise, for damages arising out of incorrect installation or use of the machines, or in any case, occasioned by the failure to observe the manufacturer's instructions.

6) TROUBLESHOOTING

6.1) Start-up difficulties

The motor's static torque is not sufficient to reach the required working speed revolutions. As a result, the temperature relay cuts the motor off:

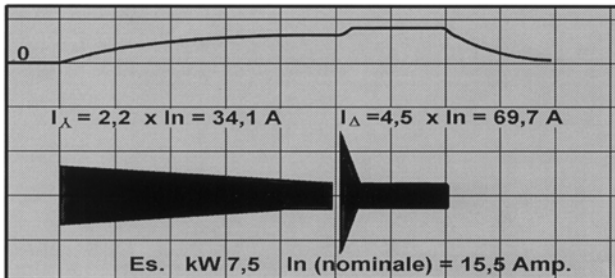
Causes:	Solution:
Reduced mains voltage	Check mains voltage.
Lack of phasing at mains	Check the mains and related electrical connections
Disactivation of the magnetic starter (when using star-delta starting) when passing to higher voltage	Check the activation time of the first connection.
Bear in mind that star-delta passage must take place only when current stabilises at a lower value after peaking, as illustrated in figure	
Disactivation of the magnetic starter (when using star-delta starting) when passing to higher voltage	Check that the rotation direction is the same at both connections
Motor torque insufficient to overcome the PD2 of the motor impeller	Call our technical dept. The motor installed has incorrect parameters
The magnetic starter has incorrect parameters for the power absorbed	Replace the magnetic starter

6.2) Insufficient air flux

Causes:	Solution:
Impeller opposite direction of rotation	Check the impeller rotation direction
Transmission belts slipping (only SIT model)	Check that the belts do not slip
Perdite del circuito superiori a quelle previste in progetto	Check that leaks in the circuit do not exceed the levels projected during design. To measure air speed inside the tubes, choose a linear stretch of tubing, preferably upstream of the fan. Use a Pitot tube to read air speed and flux. If the speed-read is lower than the values indicated in the project drawings, the defect most probably lies in the circuit.
A fan scaled to work with cold air at sea level will produce less pressure at higher altitudes or when working with hot gases.	

6.3) Excessive air flux

Causa:	Soluzione:
The loss of charge in the circuit is not inferior to the values projected in the drawings	In order to verify the air speed inside pipeline, a straight section before the fan has to be chosen. The air speed and the volume have to be measured by Pitot tube. It may be necessary to insert air locks or adjusters in the circuit to increase loss of charge.
The loss of charge in the circuit is not inferior to the values projected in the drawings	
Losses of pressure inside circuit lower to design values (only for belts and pulleys fans)	With a belt driven fan, rotation speed can be reduced by replacing pulleys, with a consequent loss in flux.

6.4) Air pulsation

Air pulsation (pumping effect) is caused by flux instability, which may be due to several factors:

- 1) Fans that operate with flux close to zero
- 2) Unstable conditions at the air inlet;

6.5) Noise

All fans generate noise.

Noise may be generated by air or by the electrical or mechanical parts of the fan.

A) Mechanical noise

If occasioned by parts rubbing against each other, the source is normally very obvious.

Otherwise attention should be paid to bearings and vibrating plates.

B) Electric noise

Besides intrinsic defects such as eccentricity between rotor and stator or porosity in the material used for the rotors, vibrations of windings etc., electric noise is always present because of harmonic generated by electromagnetic waves. In single-phase motors where the magnetic field is not symmetrical, noise can be significantly increased, depending on the amplifications caused by parts in sheet metal such as the Archimedean screw, anchor bases, foundation base, etc. In order to conform to ever stricter regulations on

noise containment, we can supply ventilating parts enclosed in soundproofed cabins and equipped with silencers at the air suction and pusher inlets.

6.6) Vibrations

It is not possible to establish generally applicable absolute values for vibration intensity that determine a good working state or dangerous conditions, since the machines and their functional features are too varied. Indeed, in some cases identical machines installed under different conditions require different evaluation criteria.

Unacceptable vibration levels may derive from imbalances or unsuitable support structures or a combination of both.

When the natural frequency of a support structure approaches the frequency of the fan rotation speed, no amount of balancing can eliminate vibration. However, the natural resonance frequency of the support structure can be significantly altered by the addition of weights. In the case of excessive imbalance, contact the manufacturer or a vibration specialist..

7) SPARE PARTS

For spare parts order please contact our company, Please, remember to write the model and the serial number of the fan:

SAVIO S.r.l.

Via Reggio Calabria 13

10090 Cascine Vica Rivoli (TO) ITALIA

Phone +39.011.959.16.01 Fax +39.011.959.29.62 E-mail: savio@savioclima.it



Via Reggio Calabria,13 – Cascine Vica Rivoli (TO) Italia
 Tel: (+39) 011. 959.16.01 Fax: (+39) 011. 959.29.62
 E-mail : savio@savioclima.it [http:// www.savioclima.it](http://www.savioclima.it)

